

Wedge Anchor BZ plus

Steel, zinc plated



Wedge Anchor BZ plus s



Wedge Anchor BZ plus



Wedge Anchor BZ-U plus /
Wedge Anchor BZ-UH plus



Wedge Anchor BZ plus
M24/M27



Range of Loading: 2,4 kN–96,8 kN
Range of concrete quality: C20/25–C50/60

Description

Due to its high performance as well as its easy and quick installation, the wedge anchor BZ plus with European Technical Assessment can be used for a wide variety of applications. The long thread length and two approved anchorage depths allow the BZ plus wedge anchor greater flexibility of use. The option for reduced anchorage depth saves time during drilling and reduces the installation effort. Using a suction drill also eliminates the need for blowing out the drilled hole.

The wedge anchors BZ plus M8–M20 are also approved for use under seismic loading C1 and C2 up to an anchor length of 210 mm¹⁾. By using the VS²⁾ filling washer, the permissible seismic loads can be increased even further.

The sherardized wedge anchor BZ plus sh version with a zinc thickness of more than 40 µm offers increased corrosion protection compared to zinc electroplating.

For timber construction, the BZ-UH-plus version is available packaged with the washer DIN EN ISO 7094 (DIN 440).

Advantages

- Approved for use in cracked and uncracked concrete (Option 1)
- Approved for seismic loads, performance categories C1 and C2 (M8 to M20, maximum anchor length 210 mm)
- Approved for use under fire exposure. Fire resistance ratings R30–R120
- Suitable for use in compression resistant natural stone (without approval)
- Two effective anchorage depths for greater flexibility (M8 to M16, maximum anchor length 210 mm)
- Anchoring with shorter effective anchorage depth reduces drilling and installation time.
- Anchoring with the standard effective anchorage depth is suitable for the highest load limits

- Particularly cost effective: the short “s” versions with only one effective anchorage depth in the sizes M8 to M16
- Suitable for surface, through, and stand-off fastening
- Suitable for sprinkler system installations complying with VdS requirements
- FM approval for the installation of sprinkler systems (M10 to M16)
- Shock approval by the Swiss Federal Office for Civil Protection

Applications

Medium to heavy duty anchorage in cracked and uncracked concrete: Steel beams, base plates, channels, tracks, wood structures.

Example of Installation

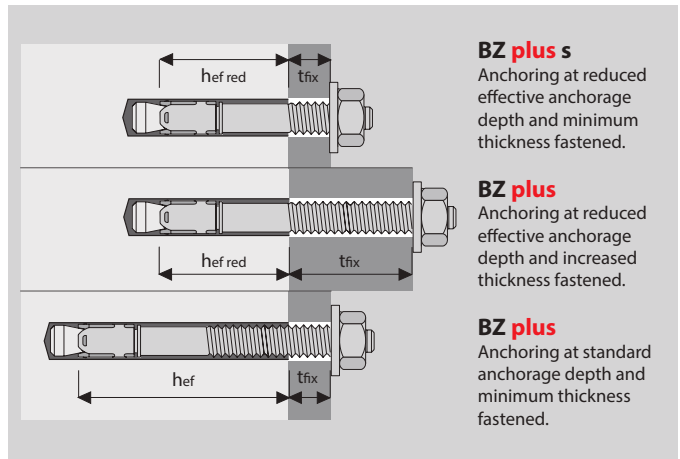

¹⁾Only standard anchorage depth

²⁾see page 96

Wedge Anchor BZ plus



- Steel, zinc plated
- Approved for cracked and uncracked concrete

Description	Ref. No.	Standard anchorage depth					Reduced anchorage depth				Anchorage length	Thread	Pkg. content	Weight per pkg.
		Max. Fixture thickness t _{fix} mm	Drill hole Ø x depth mm	Setting depth h _{nom} mm	Anchorage depth h _{ef} mm	Seismic C1 / C2	Max. Fixture thickness t _{fix,red} mm	Drill hole Ø x depth mm	Setting depth h _{nom,red} mm	Anchorage depth h _{ef,red} mm				
BZ 8-6/60 s	06105001	-	-	-	-	- / -	6	8x49	41	35	60	M8x17	100	2,54
BZ 8-11/65 s	06110001	-	-	-	-	- / -	11	8x49	41	35	65	M8x22	100	2,69
BZ 8-10-21/75	06115001	10	8x60	52	46	✓ / ✓	21	8x49	41	35	75	M8x32	100	2,99
BZ 8-15-26/80	06125001	15	8x60	52	46	✓ / ✓	26	8x49	41	35	80	M8x37	100	3,14
BZ 8-30-41/95	06140001	30	8x60	52	46	✓ / ✓	41	8x49	41	35	95	M8x52	100	3,60
BZ 8-50-61/115	06150001	50	8x60	52	46	✓ / ✓	61	8x49	41	35	115	M8x72	100	4,24
BZ 8-100-111/165	06170001	100	8x60	52	46	✓ / ✓	111	8x49	41	35	165	M8x122	50	2,94
BZ 10-10/70 s	06205001	-	-	-	-	- / -	10	10x55	48	40	70	M10x22	50	2,44
BZ 10-20/80 s	06210001	-	-	-	-	- / -	20	10x55	48	40	80	M10x32	50	2,69
BZ 10-10-30/90	06215001	10	10x75	68	60	✓ / ✓	30	10x55	48	40	90	M10x42	50	2,94
BZ 10-15-35/95	06220001	15	10x75	68	60	✓ / ✓	35	10x55	48	40	95	M10x47	50	3,06
BZ 10-20-40/100	06225001	20	10x75	68	60	✓ / ✓	40	10x55	48	40	100	M10x52	50	3,18
BZ 10-30-50/110	06230001	30	10x75	68	60	✓ / ✓	50	10x55	48	40	110	M10x62	50	3,44
BZ 10-50-70/130	06235001	50	10x75	68	60	✓ / ✓	70	10x55	48	40	130	M10x82	50	3,95
BZ 10-75-95/155	06250001	75	10x75	68	60	✓ / ✓	95	10x55	48	40	155	M10x107	50	4,55
BZ 10-100-120/180	06260001	100	10x75	68	60	✓ / ✓	120	10x55	48	40	180	M10x132	50	5,16
BZ 10-150/230	06270001	150	10x75	68	60	- / -	-	-	-	-	230	M10x80	25	3,49
BZ 12-10/85 s	06305001	-	-	-	-	- / -	10	12x70	60	50	85	M12x26	25	2,10
BZ 12-20/95 s	06310001	-	-	-	-	- / -	20	12x70	60	50	95	M12x36	25	2,28
BZ 12-10-30/105	06313001	10	12x90	80	70	✓ / ✓	30	12x70	60	50	105	M12x46	25	2,49
BZ 12-15-35/110	06315001	15	12x90	80	70	✓ / ✓	35	12x70	60	50	110	M12x51	25	2,55
BZ 12-20-40/115	06320001	20	12x90	80	70	✓ / ✓	40	12x70	60	50	115	M12x56	25	2,66
BZ 12-30-50/125	06325001	30	12x90	80	70	✓ / ✓	50	12x70	60	50	125	M12x66	25	2,84
BZ 12-50-70/145	06330001	50	12x90	80	70	✓ / ✓	70	12x70	60	50	145	M12x86	25	3,23
BZ 12-65-85/160	06335001	65	12x90	80	70	✓ / ✓	85	12x70	60	50	160	M12x101	25	3,49
BZ 12-85-105/180	06340001	85	12x90	80	70	✓ / ✓	105	12x70	60	50	180	M12x121	25	3,84
BZ 12-105-125/200	06345001	105	12x90	80	70	✓ / ✓	125	12x70	60	50	200	M12x135	25	4,21
BZ 12-125/220	06350001	125	12x90	80	70	- / -	-	-	-	-	220	M12x80	25	4,93
BZ 12-145/240	06355001	145	12x90	80	70	- / -	-	-	-	-	240	M12x80	20	4,32
BZ 12-160/255	06360001	160	12x90	80	70	- / -	-	-	-	-	255	M12x80	20	4,59
BZ 12-190/285	06370001	190	12x90	80	70	- / -	-	-	-	-	285	M12x80	20	4,99
BZ 16-5/105 s	06505001	-	-	-	-	- / -	5	16x90	77	65	105	M16x26	20	3,48
BZ 16-15/115 s	06510001	-	-	-	-	- / -	15	16x90	77	65	115	M16x36	20	3,76
BZ 16-15-35/135	06520001	15	16x110	97	85	✓ / ✓	35	16x90	77	65	135	M16x56	20	4,32
BZ 16-25-45/145	06525001	25	16x110	97	85	✓ / ✓	45	16x90	77	65	145	M16x66	20	4,60
BZ 16-50-70/170	06530001	50	16x110	97	85	✓ / ✓	70	16x90	77	65	170	M16x91	20	5,26
BZ 16-80-100/200	06535001	80	16x110	97	85	✓ / ✓	100	16x90	77	65	200	M16x121	10	3,20
BZ 16-100/220	06540001	100	16x110	97	85	- / -	-	-	-	-	220	M16x80	10	3,50
BZ 16-140/260	06550001	140	16x110	97	85	- / -	-	-	-	-	260	M16x80	10	4,12
BZ 16-180/300	06560001	180	16x110	97	85	- / -	-	-	-	-	300	M16x80	10	4,74
BZ 20-30/165	06615101	30	20x125	114	100	✓ / ✓	-	-	-	-	165	M20x50	10	4,41
BZ 20-60/195	06625101	60	20x125	114	100	✓ / ✓	-	-	-	-	195	M20x70	10	5,05
BZ 20-100/235	06630101	100	20x125	114	100	- / -	-	-	-	-	235	M20x80	5	3,04
BZ 20-130/265	06635101	130	20x125	114	100	- / -	-	-	-	-	265	M20x80	5	3,43
BZ 20-150/285	06640101	150	20x125	114	100	- / -	-	-	-	-	285	M20x80	5	3,66
BZ 24-30/190	06715101	30	24x145	133	115	- / -	-	-	-	-	190	M24x55	10	6,85
BZ 24-60/220	06725101	60	24x145	133	115	- / -	-	-	-	-	220	M24x85	5	3,93
BZ 24-75/235	06735101	75	24x145	133	115	- / -	-	-	-	-	235	M24x100	5	4,15
BZ 24-100/260	06745101	100	24x145	133	115	- / -	-	-	-	-	260	M24x125	5	4,52
BZ 27-30/210	06815101	30	28x160	146	125	- / -	-	-	-	-	210	M27x62	5	5,10
BZ 27-60/240	06825101	60	28x160	146	125	- / -	-	-	-	-	240	M27x92	5	5,60
BZ 27-100/280	06845101	100	28x160	146	125	- / -	-	-	-	-	280	M27x132	5	6,40

Mechanical Heavy Duty Anchors

Wedge Anchor-Setting Tool BSW



- Setting Tool for Wedge Anchor M6 – M16
- With SDS plus connection

Description	Ref. No.	Suitable for Wedge Anchor	Length mm	Package content pcs.	Weight per pkg. kg
BSW M6-M16	43990101	BZ3/BZ plus/B M6 – M16	140	1	0,13